



ROHS

SPECIFICATION OF PRODUCT

承认书

CUSTOMER: _____

DESCRIPTION: Piezo Buzzer

FUSHENG P/N: FUET-1030H

CUSTOMER P/N: _____

DATE: 2021-9-18

CUSTOMER	APPROVER	CHECKER
	Cui	Bing Yan

泰州福声电子科技有限公司

地址:江苏省泰州市海陵区凤凰西路 98 号

电话: 0523-86219066

邮箱: sales@electronic-tech.cn

网址: www.tzfsdz.com



1.SPECIFICATION 规格

No.	Item	Unit	Specification	Condition
1	Oscillation Frequency	Hz	5200	square wave
2	Operating Voltage	Vp-p	1 ~ 25	
3	Rated Voltage	Vp-p	5	
4	Current Consumption	mA	MAX. 3	at Rated Voltage
5	Sound Pressure Level	dB	MIN. 70	at 10cm at Rated Voltage
6	Electrostatic Capacity	pF	12000±30%	at 100Hz 1V
7	Operating Temperature	°C	-20 ~ +70	
8	Storage Temperature	°C	-30 ~ +80	
9	Dimension	mm	10 x 10 x H 3.0	See appearance drawing
10	Weight (MAX)	gram	0.3	
11	Housing Material		LCP(Black)	
12	Leading Pin		Tin Plated Brass(Sn)	See appearance drawing
13	Environmental Protection Regulation		RoHS	

2. APPEARANCE DRAWING 尺寸图

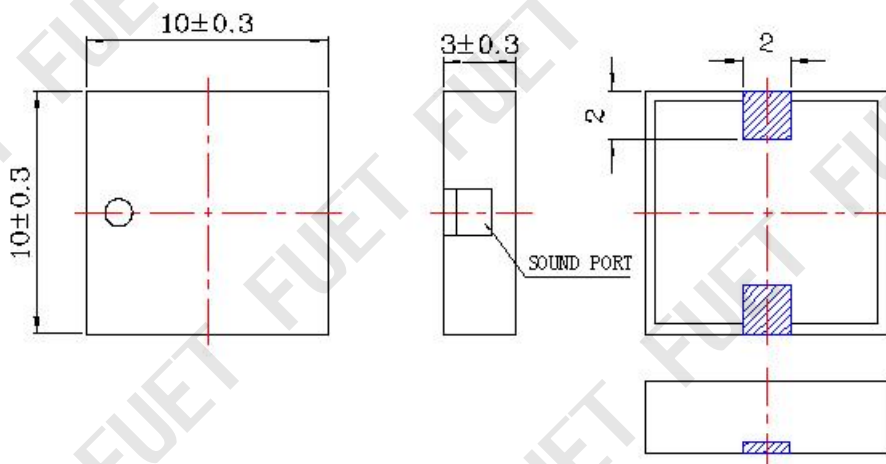

Tol : ± 0.3 Unit: mm

3. TESTING METHOD 测量方式

Standard Measurement conditions

Temperature: $25 \pm 2^\circ\text{C}$ Humidity: 45-65%

Acoustic Characteristics:

The oscillation frequency, current consumption and sound pressure are measured by the measuring instruments shown below.

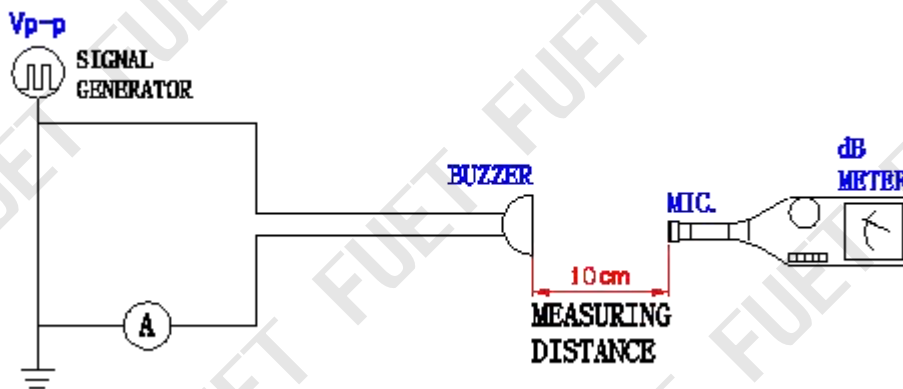

In the measuring test, buzzer is placed as follows:

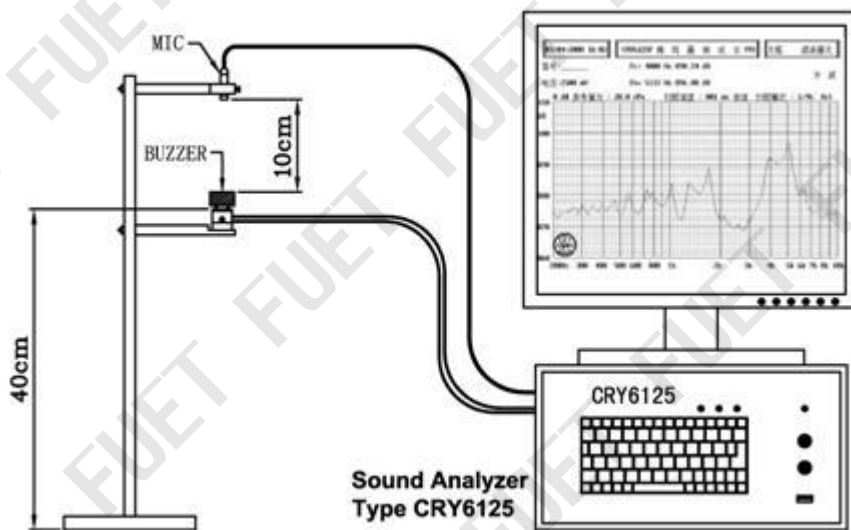

4. Typical Frequency Response Curve

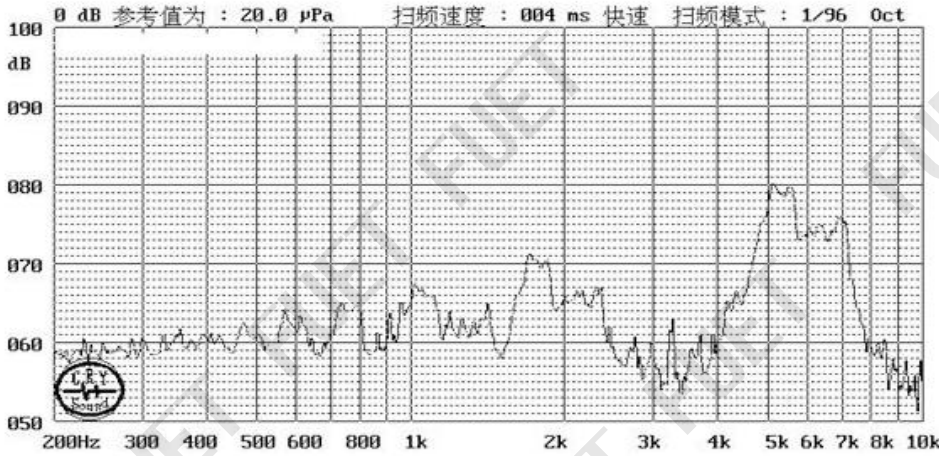

5.Soldering Condition

(1)Recommendable reflow soldering condition is as follows
 (Reflow soldering is twice)

Note:It is requested that reflow soldering should be executed
 after heat of product goes down to normal.

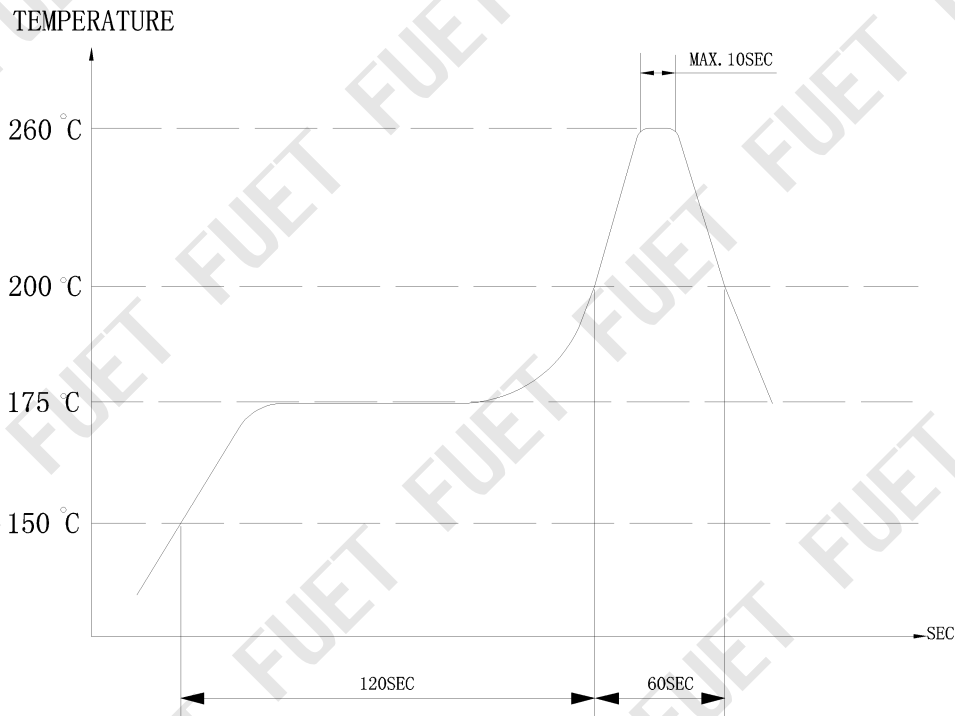

Heat resistant line
 (Used when heat resistant reliability test is performed)

(2)Manual soldering
 Manual soldering temperature 350 °C within 5 sec.

6. RELIABILITY TEST

NO.	ITEM	TEST CONDITION AND REQUIREMENT
1	High Temperature Test (Storage)	After being placed in a chamber with 80 °C for 96 hours and then being placed in normal condition for 2 hours. Allowable variation of SPL after test: 10dB.
2	Low Temperature Test (Storage)	After being Placed in a chamber with -30 °C for 96 hours and then being placed in normal condition for 2 hours. Allowable variation of SPL after test: 10dB.
3	Humidity Test	After being Placed in a chamber with 90-95% R.H. at 40 °C for 96 hours and then being placed in normal condition for 2 hours. Allowable variation of SPL after test: 10dB.
4	Temperature Cycle Test	The part shall be subjected to 5 cycles. One cycle shall be consist of:  <p>The diagram shows a temperature cycle profile over 3 hours. It starts at -20°C for 0.5 hours, then ramps up to +25°C in 0.5 hours, holds at +25°C for 0.25 hours, ramps up to +70°C in 0.5 hours, holds at +70°C for 0.5 hours, ramps down to +25°C in 0.5 hours, holds at +25°C for 0.25 hours, and finally ramps down to -20°C in 0.5 hours. The total duration is 3 hours.</p> Allowable variation of SPL after test: 10dB.
5	Drop Test	Drop on a hard wood board of 4cm thick, any directions ,6 times, at the height of 75cm . Allowable variation of SPL after test: 10dB.
6	Vibration Test	After being applied vibration of amplitude of 1.5mm with 10 to 55 Hz band of vibration frequency to each of 3 perpendicular directions for 2 hours . Allowable variation of SPL after test: 10dB.
7	Solderability Test	Lead terminals are immersed in rosin for 5 seconds and then immersed in solder bath of +300 °C for 3 1 seconds . 90% min. lead terminals shall be wet with solder (Except the edge of terminals).
8	Terminal Strength Pulling Test	The force of 9.8N(1.0kg) is applied to each terminal in axial direction for 10 seconds. No visible damage and cutting off.

TEST CONDITION.

Standard Test Condition	:	a) Temperature : +5 ~ +35°C	b) Humidity : 45-85%	c) Pressure : 860-1060mbar
一般测试条件	:	a) 温度 : +5 ~ +35°C	b) 湿度 : 45-85%	c) 气压 : 860-1060mbar
Judgment Test Condition	:	a) Temperature : +25 ± 2°C	b) Humidity : 60-70%	c) Pressure : 860-1060mbar
争议时测试条件	:	a) 温度 : +25 ± 2°C	b) 湿度 : 60-70%	c) 气压 : 860-1060mbar

7. PACKING STANDARD

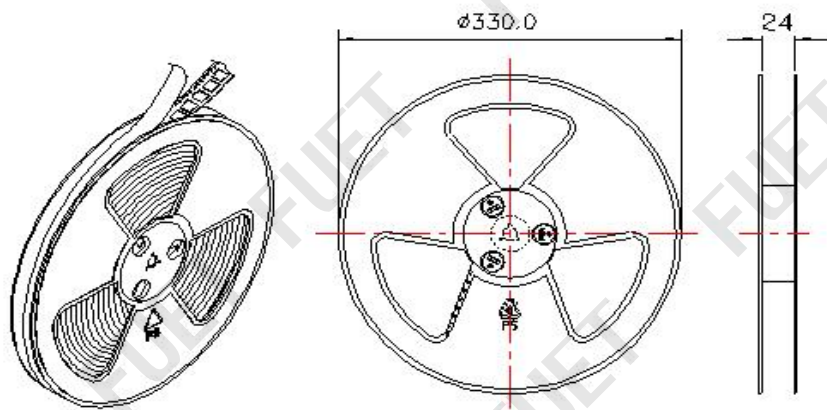

1 Reel : 1000PCS

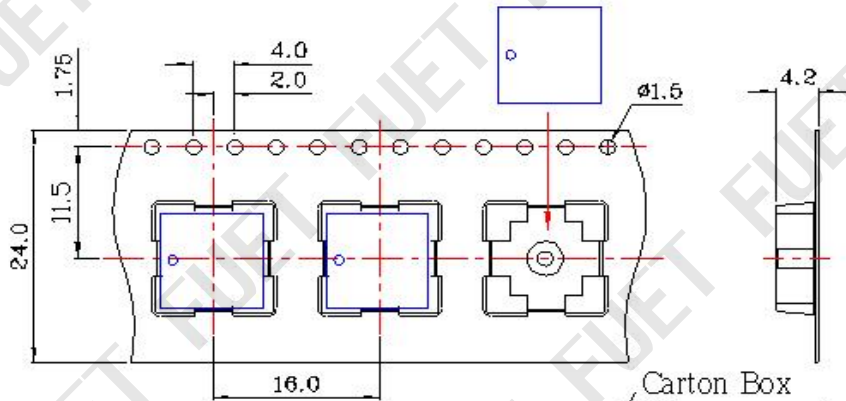

Carton Box
(10 Inner Box)

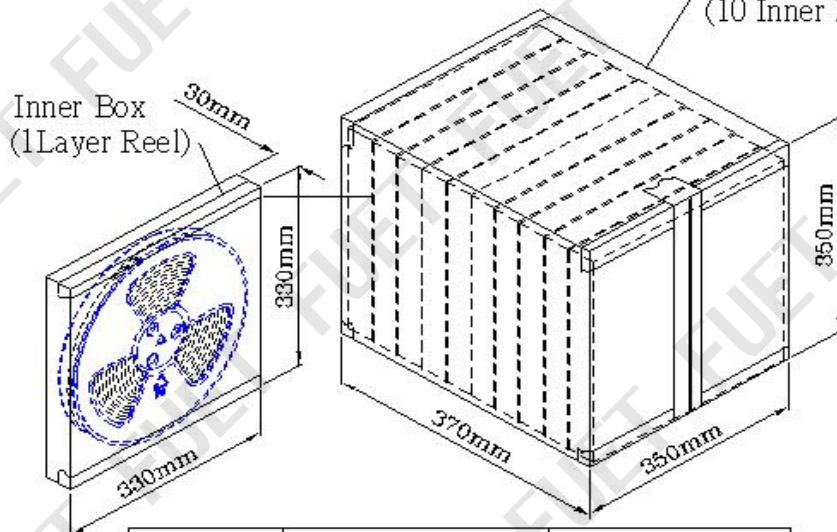

Inner Box	330mmx330mmx30mm	1x1000PCS=1000PCS
Carton Box	350mmx350mmx370mm	10x1000PCS=10,000PCS