



ROHS

SPECIFICATION OF PRODUCT

承认书

CUSTOMER: _____

DESCRIPTION: Piezo Buzzer

FUSHENG P/N: FSD-2312

CUSTOMER P/N: _____

DATE: 2018-8-28

CUSTOMER	APPROVER	CHECKER
	Yunqing Wu	Bing Yan

泰州福声电子科技有限公司

地址:江苏省泰州市海陵区凤凰西路 168 号

电话: 0523-83724803 传真: 0523-83724866

邮箱: akinn@electronic-tech.cn

网址: www.tzfsdz.com



1.SPECIFICATION 规格

No.	Item	Unit	Specification	Condition
1	Oscillation Frequency	Hz	3300±500	
2	Operating Voltage	VDC	3 ~ 20	
3	Rated Voltage	VDC	12	
4	Current Consumption	mA	MAX. 10	at Rated Voltage
5	Sound Pressure Level	dB	MIN. 85	at 10cm at Rated Voltage
6	Operating Temperature	°C	-20 ~ +70	
7	Storage Temperature	°C	-30 ~ +85	
8	Dimension	mm	Φ23.0 x H12	See appearance drawing
9	Weight (MAX)	gram	4	
10	Housing Material		ABS(Black)	
11	Leading Pin		Wire Type	See appearance drawing
12	Environmental Protection Regulation		RoHS	

2. APPEARANCE DRAWING 尺寸图

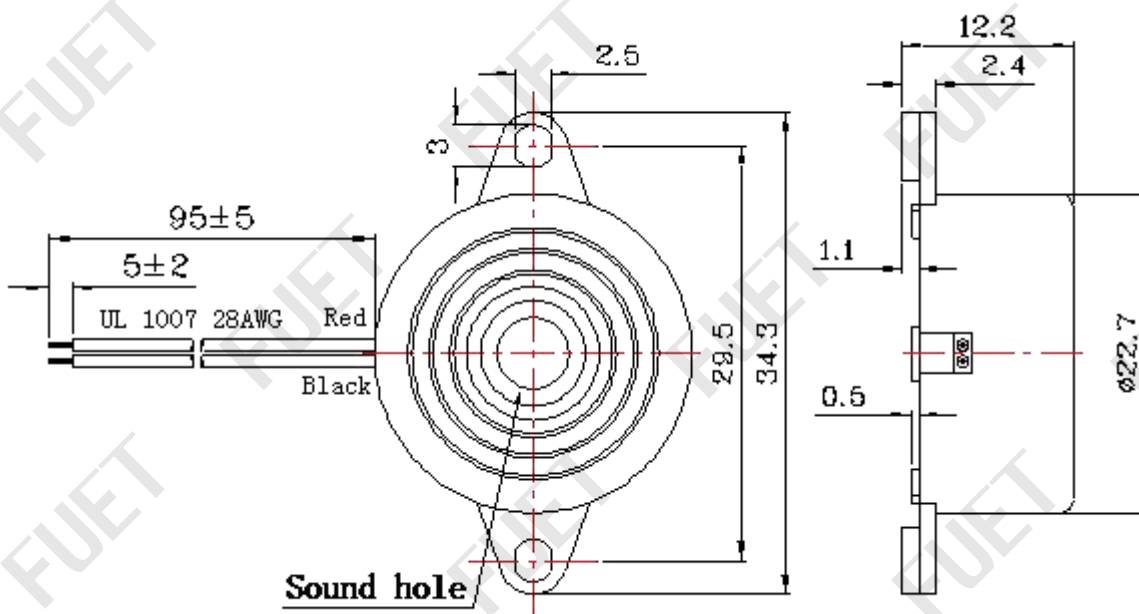

3. TESTING METHOD 测量方式

Standard Measurement conditions

Temperature: $25 \pm 2^\circ\text{C}$ Humidity: 45-65%

Acoustic Characteristics:

The oscillation frequency, current consumption and sound pressure are measured by the measuring instruments shown below

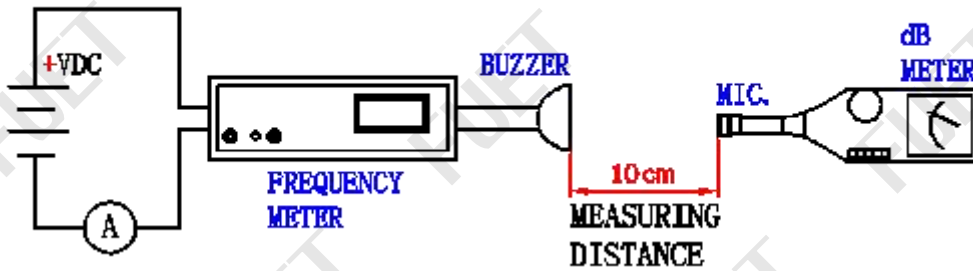

In the measuring test, buzzer is placed as follows:

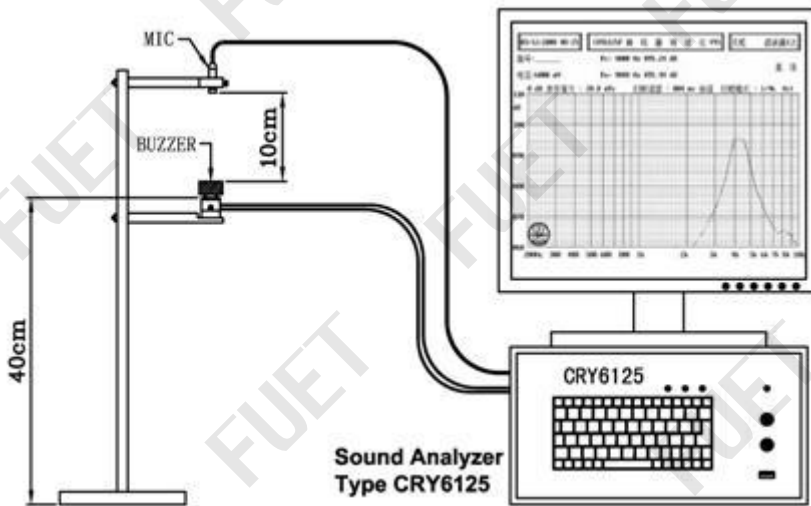

4. VOLTAGE / CURRENT / SOUND PRESSURE CHARACTERISTICS

dB-V

mA-V

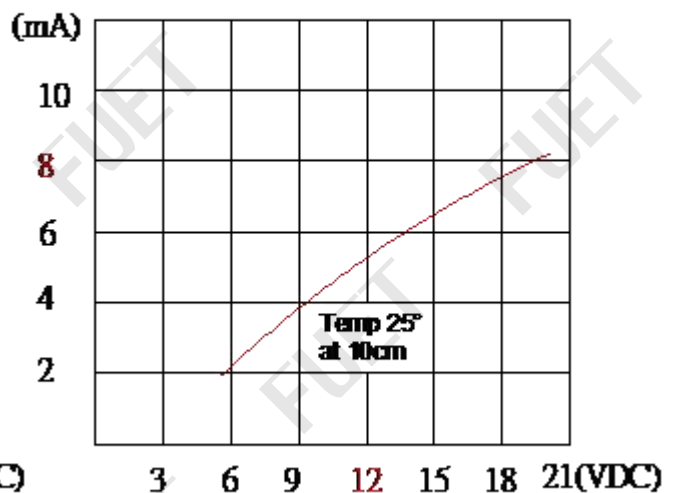
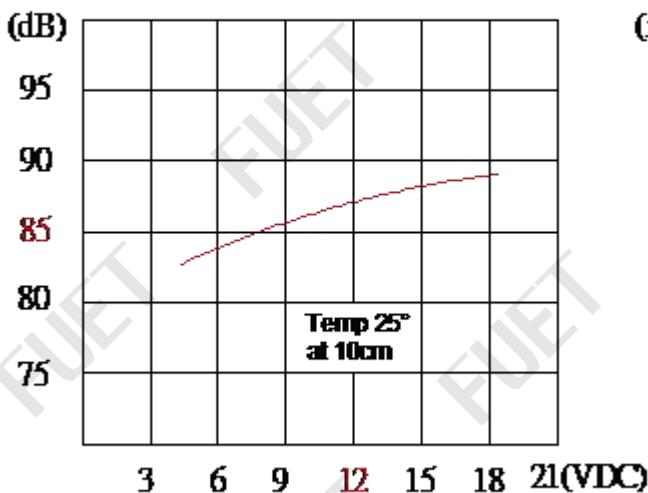

5. RELIABILITY TEST 可靠性测试

NO.	ITEM	TEST CONDITION AND REQUIREMENT
1	High Temperature Test (Storage)	After being placed in a chamber with 80 °C for 96 hours and then being placed in normal condition for 2 hours. Allowable variation of SPL after test: 10dB.
2	Low Temperature Test (Storage)	After being Placed in a chamber with -30 °C for 96 hours and then being placed in normal condition for 2 hours. Allowable variation of SPL after test: 10dB.
3	Humidity Test	After being Placed in a chamber with 90-95% R.H. at 40 °C for 96 hours and then being placed in normal condition for 2 hours. Allowable variation of SPL after test: 10dB.
4	Temperature Cycle Test	The part shall be subjected to 5 cycles. One cycle shall be consist of:  Allowable variation of SPL after test: 10dB.
5	Drop Test	Drop on a hard wood board of 4cm thick, any directions ,6 times, at the height of 75cm . Allowable variation of SPL after test: 10dB.
6	Vibration Test	After being applied vibration of amplitude of 1.5mm with 10 to 55 Hz band of vibration frequency to each of 3 perpendicular directions for 2 hours . Allowable variation of SPL after test: 10dB.
7	Solderability Test	Lead terminals are immersed in rosin for 5 seconds and then immersed in solder bath of +300 °C for 30 seconds . 90% min. lead terminals shall be wet with solder (Except the edge of terminals).
8	Terminal Strength Pulling Test	The force of 9.8N(1.0kg) is applied to each terminal in axial direction for 10 seconds. No visible damage and cutting off.

TEST CONDITION.

Standard Test Condition	:	a) Temperature : +5 ~ +35°C	b) Humidity : 45-85%	c) Pressure : 860-1060mbar
一般测试条件	:	a) 温度 : +5 ~ +35°C	b) 湿度 : 45-85%	c) 气压 : 860-1060mbar
Judgment Test Condition	:	a) Temperature : +25 ± 2°C	b) Humidity : 60-70%	c) Pressure : 860-1060mbar
争议时测试条件	:	a) 温度 : +25 ± 2°C	b) 湿度 : 60-70%	c) 气压 : 860-1060mbar